

Minst 1 omstart ska markeras vid svetsning av rotsträngen.
 Minst 1 omstart ska markeras vid svetsning av toppsträngen
 Denna kälsvets kommer att brytprovas.
 Svetsläge lottas tävlingsdagen.

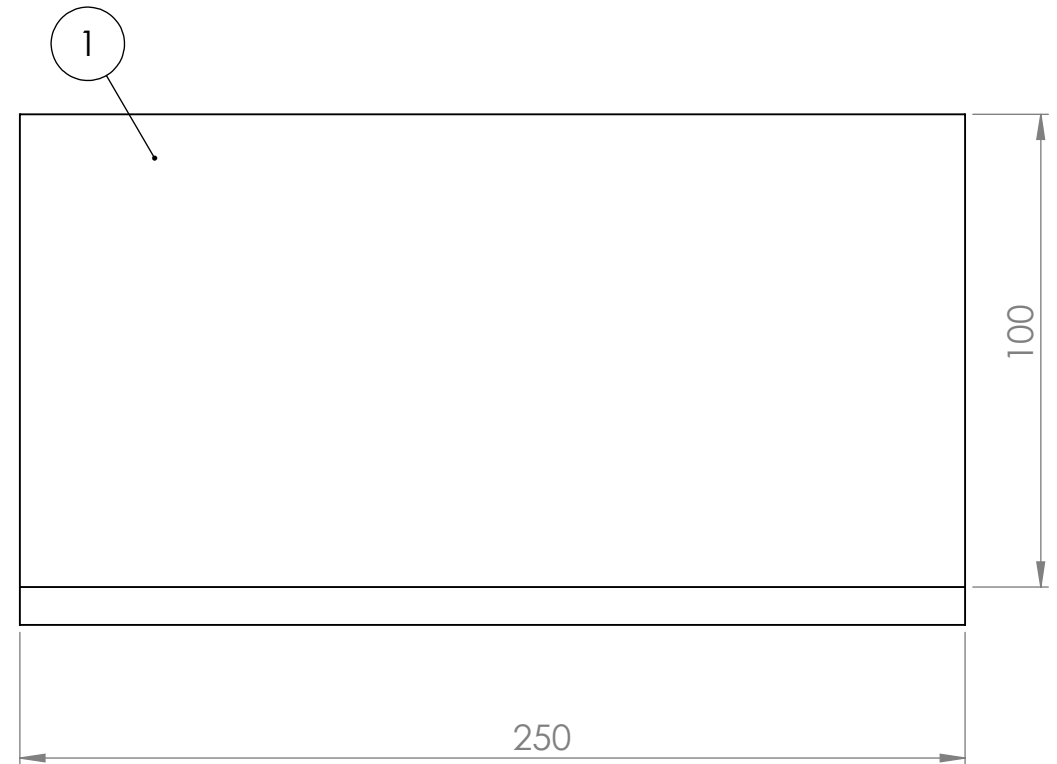
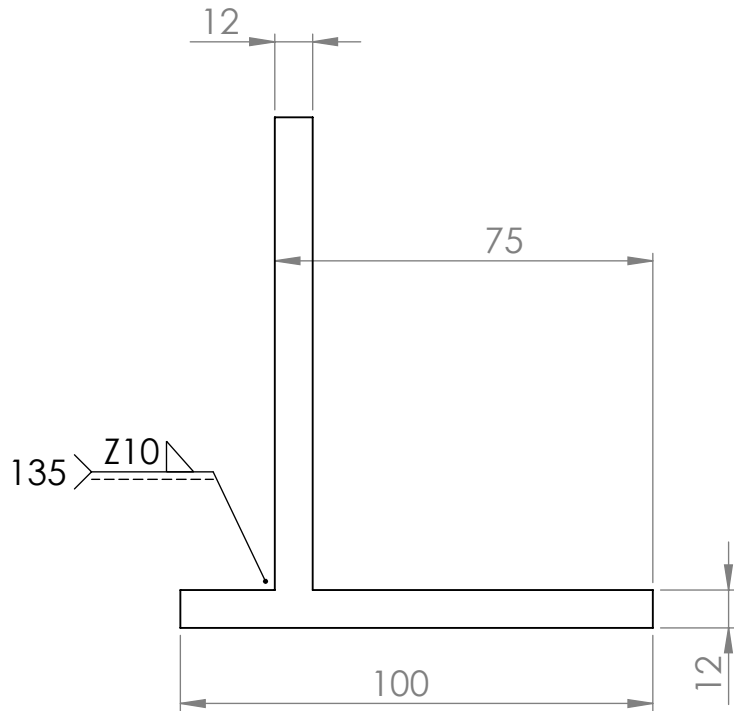

- NOTE
 -DEPOSIT A FILLET WELD ON THE FRONT SIDE OF THE JOINT WITH 10MM $-0/+2$ LEG LENGTH.
 -WELD TO BE DEPOSITED WITH A MINIMUM OF 2 RUNS AND A MAXIMUM OF 3 RUNS.
 -EDGE PREPARATIONS MUST REMAIN AT 90° TO THE PLATE FACE.
 NO CHAMFER AND GAP ALLOWED.
 -TACK WITH 25 MM LENGTH MAXIMUM.

1	2	Kälsvets	S235JR	250x100x12	1:2	4	2019-11-21
Det.nr	Antal	Benämning	Material	Dimension	Skala:	Rit.nr	Datum