

Minst 1 omstart ska markeras vid svetsning av rotsträngen.
 Minst 1 omstart ska markeras vid svetsning av toppsträngen
 Denna kälsvets kommer att brytprovas.
 Svetsläge lottas tävlingsdagen.

SVETSLÄGE

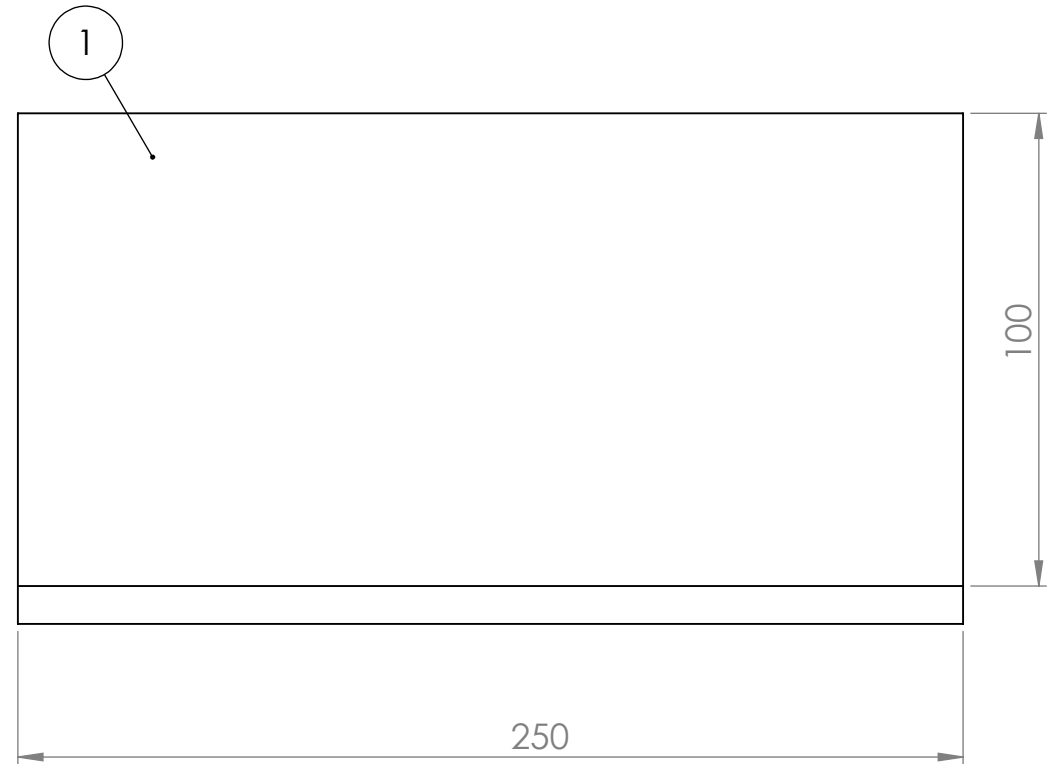
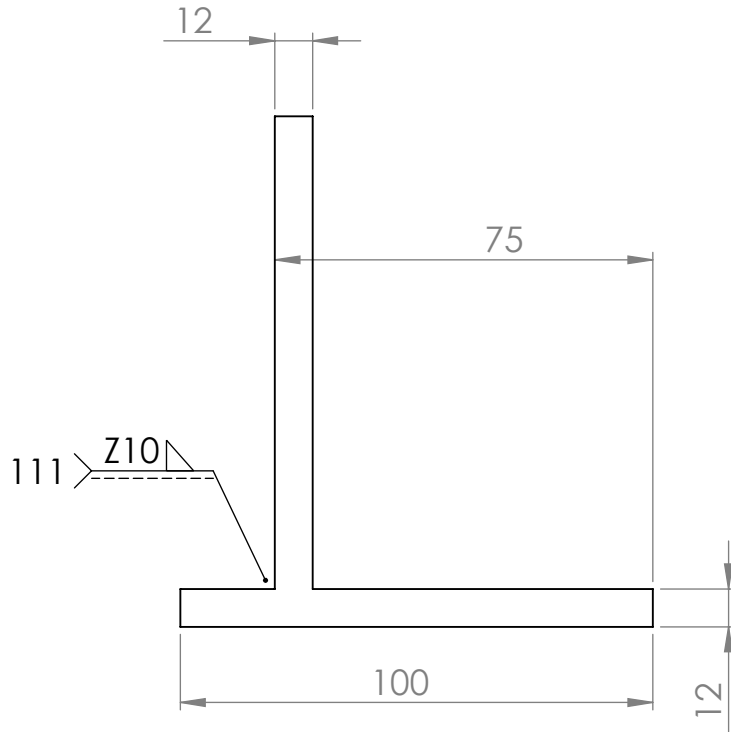

- NOTE
- DEPOSIT A FILLET WELD ON THE FRONT SIDE OF THE JOINT WITH 10MM -0/+2 LEG LENGTH.
- WELD TO BE DEPOSITED WITH A MINIMUM OF 2 RUNS AND A MAXIMUM OF 3 RUNS.
- EDGE PREPARATIONS MUST REMAIN AT 90° TO THE PLATE FACE. NO CHAMFER AND GAP ALLOWED.
- TACK WITH 25 MM LENGTH MAXIMUM.

1	2	Kälsvets	S235JR	250x100x12	1:2	5	2019-11-21
Det.nr	Antal	Benämning	Material	Dimension	Skala:	Rit.nr	Datum